

10" FIELD-ADJUSTABLE PARKING GARAGE/CANOPY

L40/70-PG10-30/50-120/277V-D-ADJ

OVERVIEW

Simply Conserve®'s field-adjustable parking garage luminaire includes two switches on the unit which allows for adjustment of the input power, lumen output, and color temperature. This downlight allows for easy installation in parking garages and/or canopies.

KEY FEATURES

- Field-adjustable lumen and CCT
- For retrofit or new construction installation
- Wet-location, IP65-rated
- L70-rated lifetime of 50,000 hours
- 0-10V dimmable
- 155° beam angle



FIELD-ADJUSTABLE



EASY TO INSTALL



50,000 HOURS



WET-RATED



ORDERING INFORMATION

SOURCE	WATTAGE	LAMP TYPE	SIZE	CCT	OPTIONS
L = LED	40/70 = 40W, 60W, 70W	PG = Parking Garage	10 = 10"	30/50 = 3000K, 4000K, 5000K	D = 0-10v Dimming ADJ = Field-Adjustable

SPECIFICATIONS

CATALOG #	WATTS	CCT	LUMENS	EFFICACY	CRI	VOLTAGE	DIM
L40/70-PG10-30/50-120/277V-D-ADJ	40/60/70W	3000/4000/5000K	4800/7200/8400	120 LPW	≥80	120V-277V	0-10V

DIMENSIONS

PRODUCT

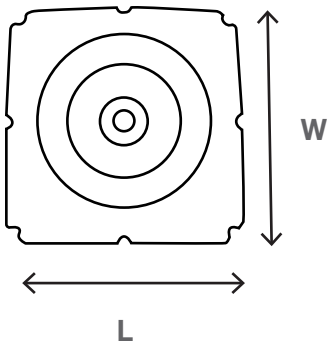
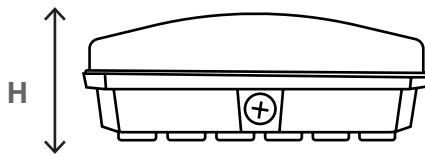

PACKAGING

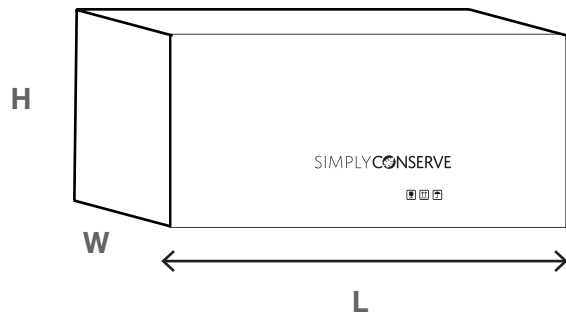

CATALOG #	L	W	H
L40/70-PG10-30/50-120/277V-D-ADJ	10.1"	10.1"	4.2"

CATALOG #	L	W	H	CASE QTY	GROSS WT
L40/70-PG10-30/50-120/277V-D-ADJ	23.2"	12.6"	12.6"	4	26.2 lbs

5-Year Limited Warranty



AM Conservation ("AMC") warrants this product to be free from manufacturing defects for a period of five years from the date of consumer purchases or distribution by an energy conservation program, and has been properly operated, AMC will replace the 10" field-adjustable parking garage/canopy free of charge.

For warranty claims, please contact:

customer@amconservation.com

To learn more, please visit:

www.amconservation.com